

Powered Two Wheel Wheelie Bin Tippler Specification Sheet

Wheelie Bins Can Become Too Heavy to Safely Empty Manually

Features

- Standalone tippler to empty 2 wheel wheelie bins into skips or 4 wheeled bins.
- Empties containers over a maximum wall height of 138 cm.
- Patented gravity auto lock comb bar anchor system
- Two braked and two un-braked wheels for easy manoeuvrability.
- Fits standard two wheel wheelie bins from 80 ltr to 360 ltr.
- High Speed lift in 14 seconds and return in 8 seconds.
- Self-contained hydraulic powered.
- Indoor or outdoor use.
- Single phase normal plug electricity supply.
- CE Approved.



Specifications

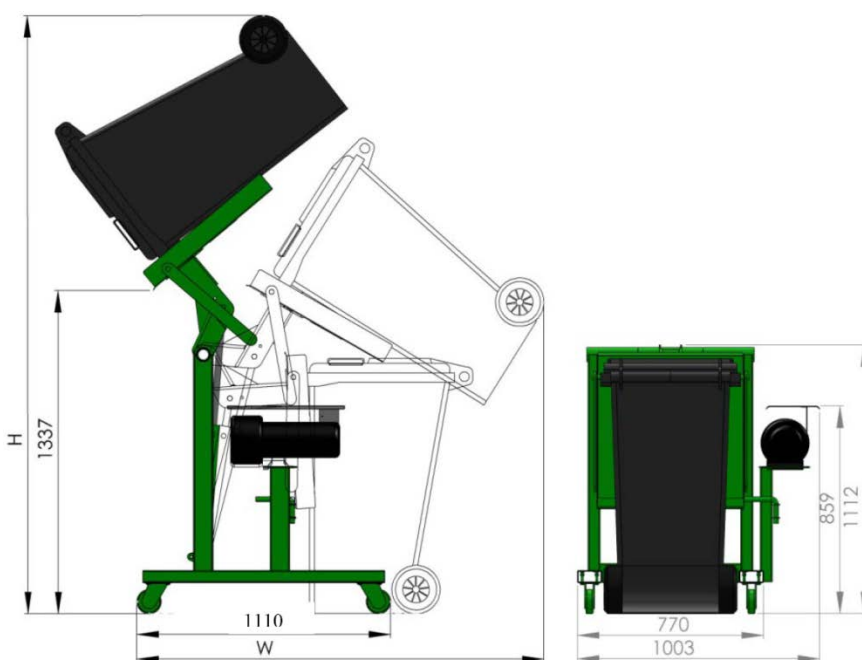

Required Indoor Operating Height (H)

- 260 cm (360 ltr)
- 248 cm (240 ltr)
- 235 cm (140 ltr)
- 228 cm (120/80 ltr)

Rated maximum load: 105 kg

Unit Weight: 100kg

Maximum Power and Voltage:
0.75KW- 230 – 240V

Maximum Amps Drawn: 4.7 amps